

SECTION A-A

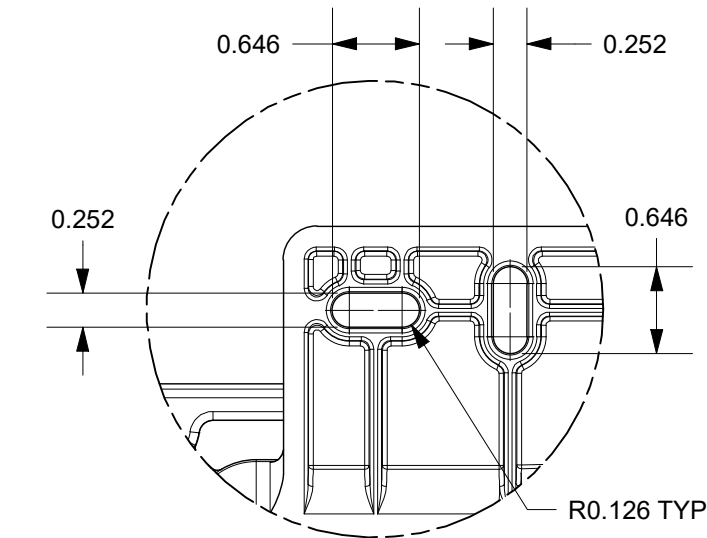

DETAIL C
(4x)

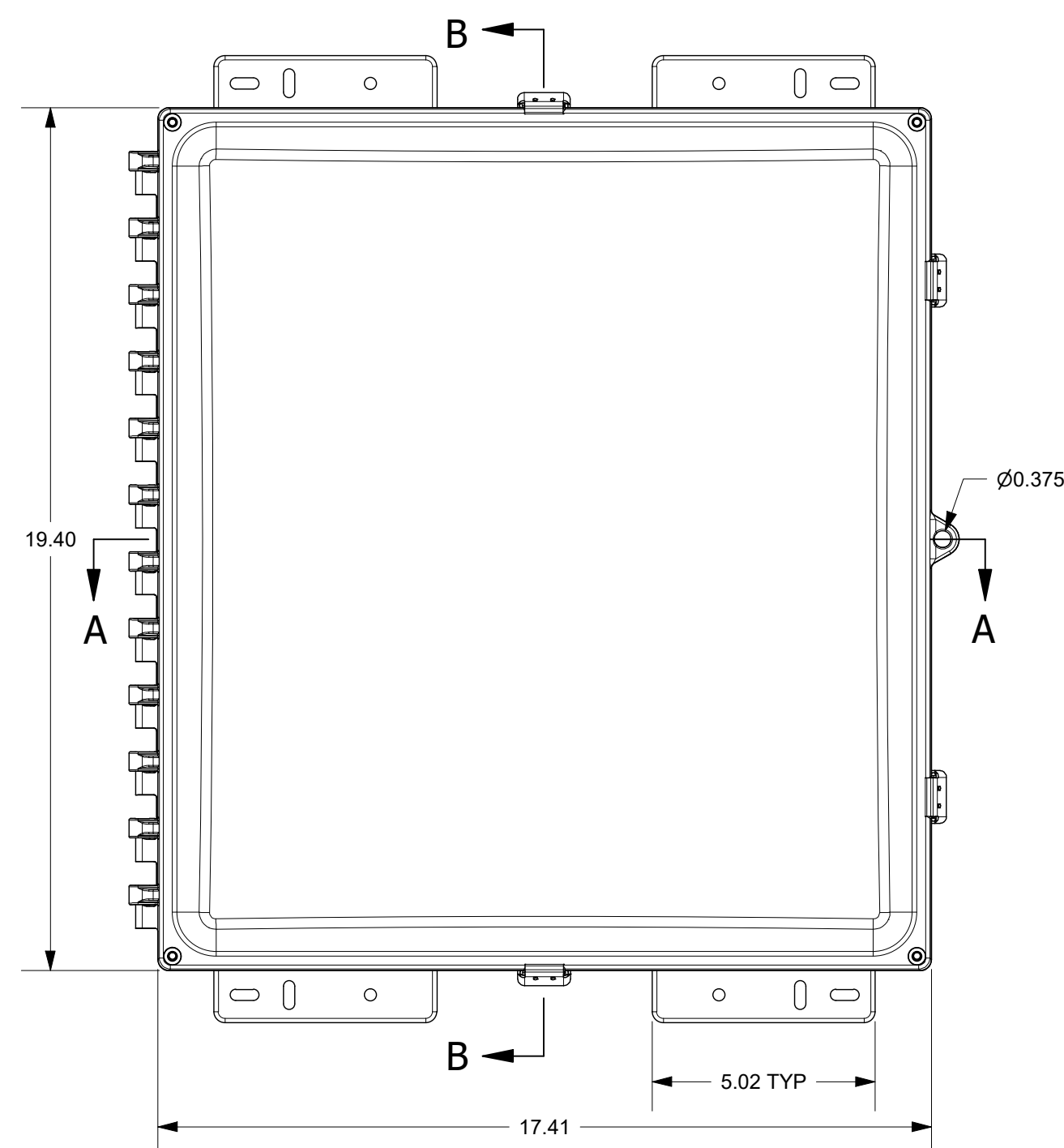
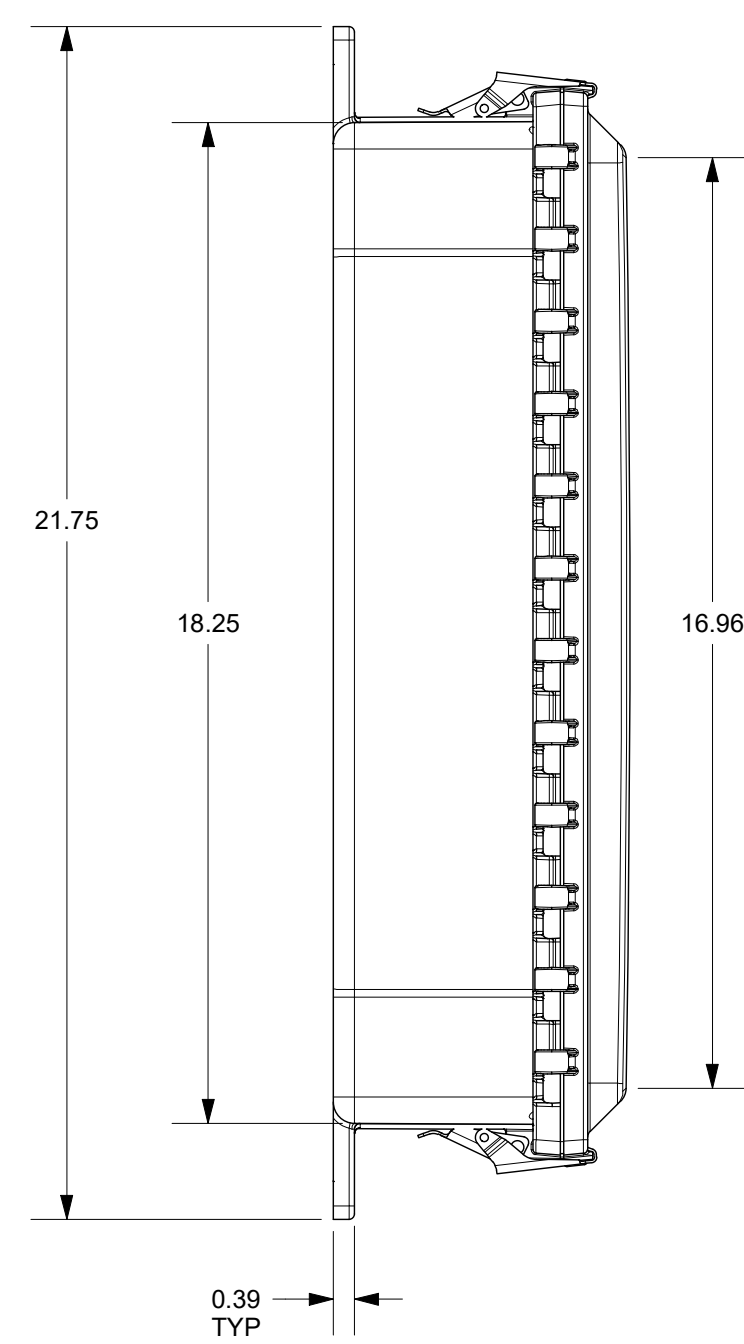
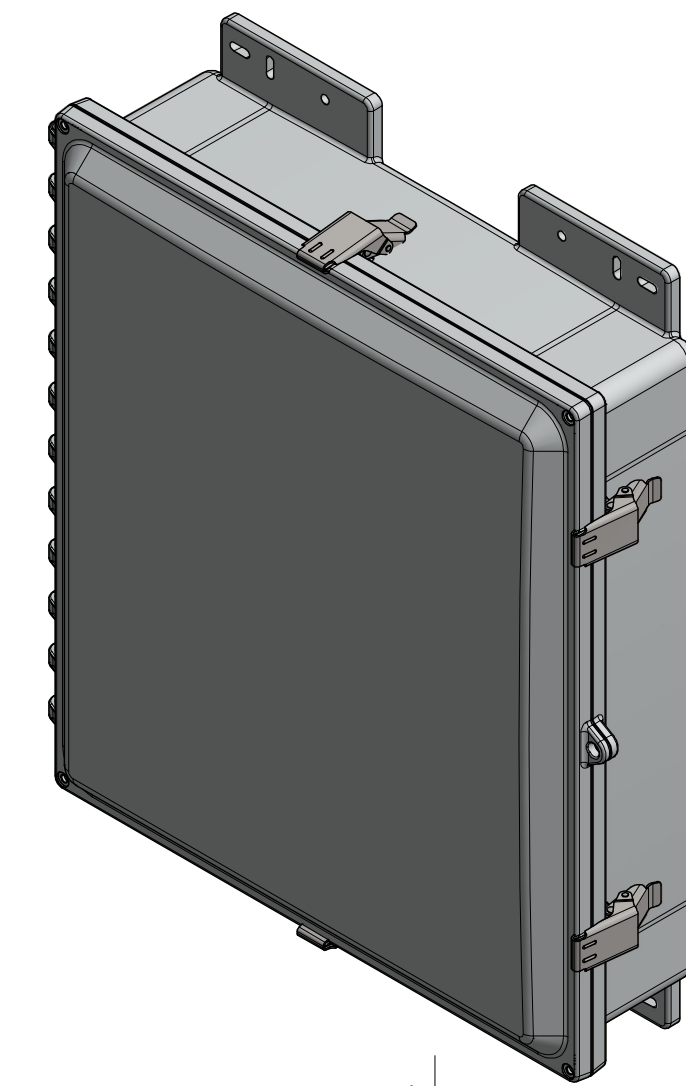

SECTION B-B

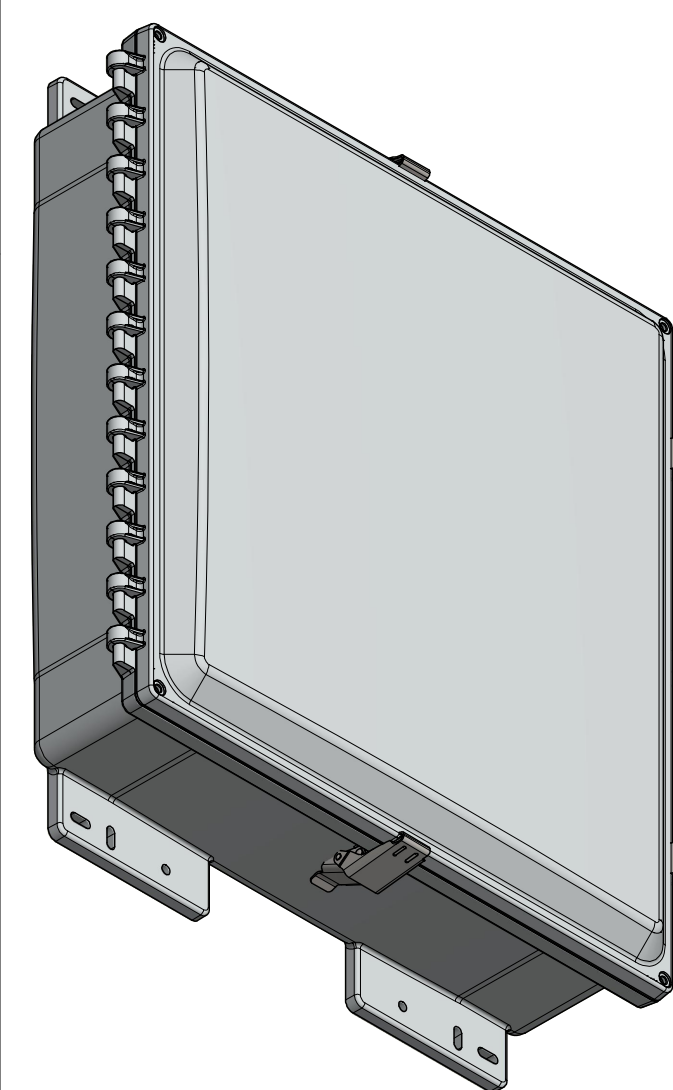
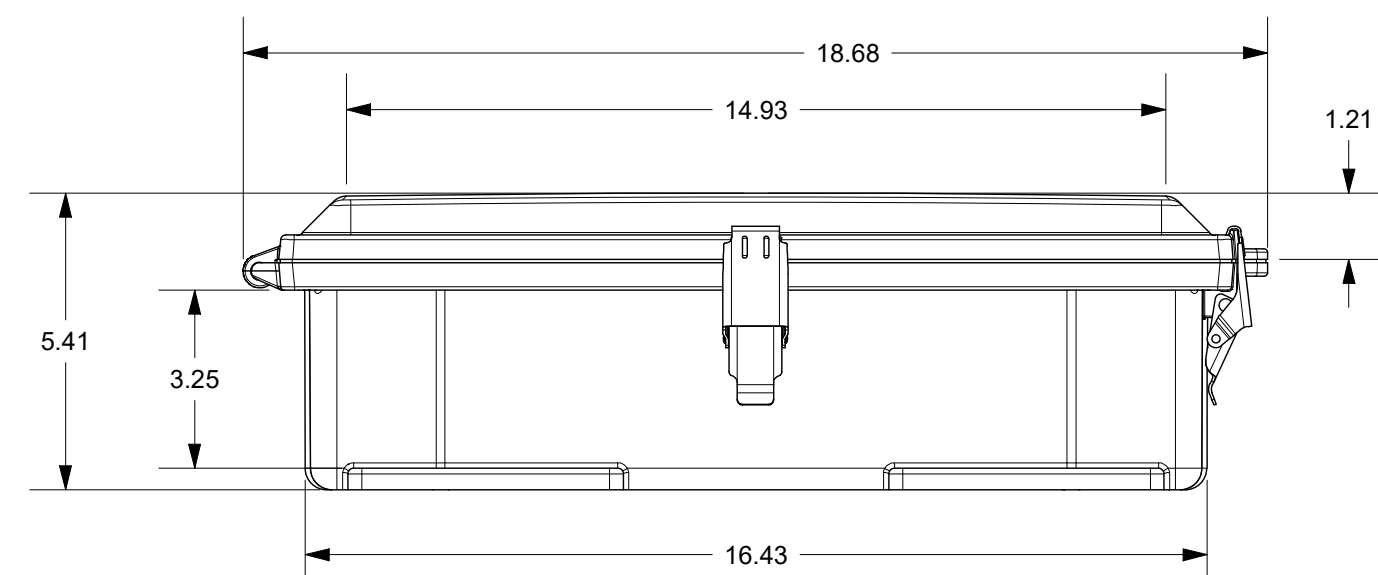
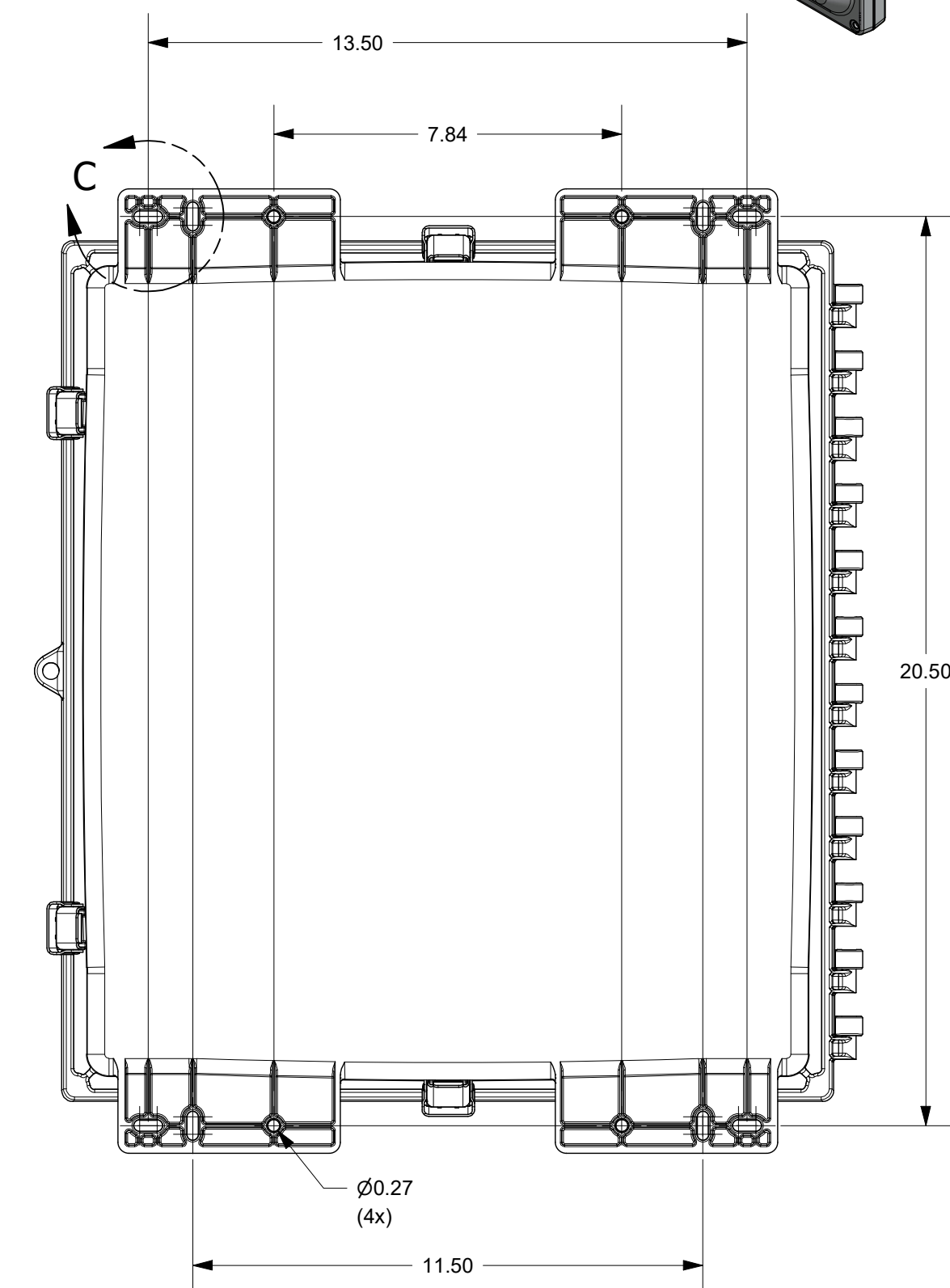
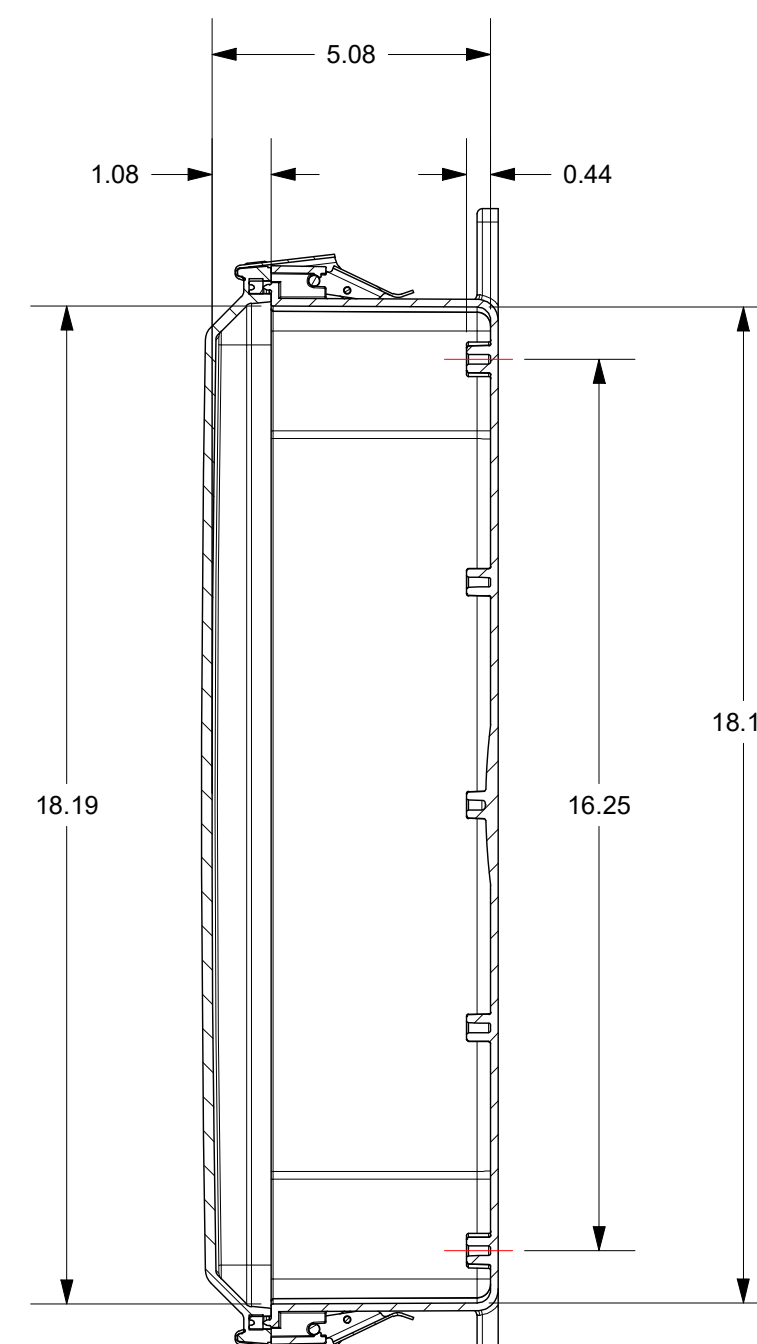

THIS DRAWING IS THE SOLE AND EXCLUSIVE PROPERTY OF ROBROY ENCLOSURES. NO PART OF THIS DRAWING MAY BE REPRODUCED, DISTRIBUTED, OR PUBLICALLY DISPLAYED IN ANY FORM OR BY ANY MEANS WITHOUT THE EXPRESS WRITTEN PERMISSION OF ROBROY ENCLOSURES. ALL RIGHTS RESERVED. UNDER THE COPYRIGHT LAWS. COPYRIGHT © 2020 ROBROY ENCLOSURES

SPECIAL REQUIREMENTS

- ASSEMBLY:**
 1. (1) POLYCARBONATE ACCESSORY KIT WITHOUT MOUNTING FEET (WPPCACCKITNOFT) SHALL BE PACKAGED LOOSELY INSIDE ENCLOSURE
HARDWARE INCLUDED:
 -(4) #10-32 x 5/8 PAN HEAD PHILLIPS MACHINE SCREW (RMSC10/32X5/8SS)
 -(4) #10-32 x 3/8 PAN HEAD SCREW (RMSC10/32X3/8ZN)
 -(4) #10 WASHER (RMWAS10ZN)
 2. (1) STYROFOAM SHEET SHALL BE PLACED ON TOP OF COVER INSIDE CARTON

NEMA 250: TYPE 1, 3R, 4, 4X, 12 IEC 60529: IP66		STANDARD P/N: AH18164SS	ALL DIMENSIONS ARE IN INCHES UNLESS OTHERWISE SPECIFIED		TOLERANCES UNLESS SPECIFIED	.XX ± 0.03	.XXX ± 0.010
COLOR: N/A COLOR STANDARD: PANTONE 7541 C		CUSTOMER DWG:	 AttaBox A ROBROY ENCLOSURES™ BRAND Robroy Enclosures 500 Maple Street Belding, Michigan 48809 Phone: 616-794-0700 Fax: 616-749-3378				
MATERIAL: POLYCARBONATE							
REVISION HISTORY		DRAWN BY	DATE	CUSTOMER		DWG	
REV	DESCRIPTION	AA	8/15/20			AH18164SS	
DO NOT SCALE		SCALE	DO NOT SCALE	DESCRIPTION	PART NUMBER		
				STANDARD ENCLOSURE	ATAH18164SS		